

**A**

ಒಟ್ಟು ಮುದ್ರಿತ ಪುಟಗಳ ಸಂಖ್ಯೆ : 12 ]

Total No. of Printed Pages : 12 ]

ಒಟ್ಟು ಪ್ರಶ್ನೆಗಳ ಸಂಖ್ಯೆ : 38 ]

Total No. of Questions : 38 ]

ಸಂಕೇತ ಸಂಖ್ಯೆ : **83-E**Code No. : **83-E****CCE RF  
CCE RR  
REVISED**Question Paper Serial No. **21**

ಇಲ್ಲಿಂದ ಕತ್ತರಿಸಿ

ವಿಷಯ : ವಿಜ್ಞಾನ

**Subject : SCIENCE**(ಭೌತಶಾಸ್ತ್ರ, ರಸಾಯನಶಾಸ್ತ್ರ ಮತ್ತು ಜೀವಶಾಸ್ತ್ರ / **Physics, Chemistry & Biology**)( ಇಂಗ್ಲಿಷ್ ಭಾಷಾಂತರ / **English Version** )( ಹೊಸ ಪಠ್ಯಕ್ರಮ / **New Syllabus** )( ಶಾಲಾ ಅಭ್ಯರ್ಥಿ & ಪುನರಾವರ್ತಿತ ಶಾಲಾ ಅಭ್ಯರ್ಥಿ / **Regular Fresh & Regular Repeater** )

ದಿನಾಂಕ : 30. 03. 2020 ]

[ Date : 30. 03. 2020

ಸಮಯ : ಬೆಳಿಗ್ಗೆ 9-30 ರಿಂದ ಮಧ್ಯಾಹ್ನ-12-45 ರವರೆಗೆ ] [ Time : 9-30 A.M. to 12-45 P.M.

ಗರಿಷ್ಠ ಅಂಕಗಳು : 80 ]

[ Max. Marks : 80

**General Instructions to the Candidate :**

1. This Question Paper consists of 38 objective and subjective types of questions.
2. This question paper has been sealed by reverse jacket. You have to cut on the right side to open the paper at the time of commencement of the examination. Check whether all the pages of the question paper are intact.
3. Follow the instructions given against both the objective and subjective types of questions.
4. Figures in the right hand margin indicate maximum marks for the questions.
5. The maximum time to answer the paper is given at the top of the question paper. It includes 15 minutes for reading the question paper.

TEAR HERE TO OPEN THE QUESTION PAPER

ಪ್ರಶ್ನೆಪತ್ರಿಕೆಯನ್ನು ತೆರೆಯಲು ಇಲ್ಲಿ ಕತ್ತರಿಸಿ

Tear here



- I. Four alternatives are given for each of the following questions / incomplete statements. Choose the correct alternative and write the complete answer along with its letter of alphabet.   $8 \times 1 = 8$



1. The inner surface of solar cooker is coated with black paint to 



- (A) absorb more heat  (B) reflect light   
 (C) prevent rusting  (D) converge the light rays.

2. As the pH value of a neutral solution increases 



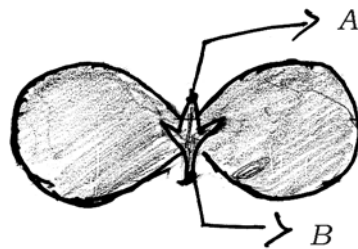





- (A) basic property decreases and number of  $\text{OH}^-$  ions increases  
 (B) acidic property increases and number of  $\text{H}^+$  ions decreases   
 (C) basic property increases and number of  $\text{OH}^-$  ions increases  
 (D) acidic property decreases and number of  $\text{H}^+$  ions increases. 

3. In the given figure of Cotyledon the parts labelled as A and B respectively are 



- (A) fruit, shoot   
 (B) primary shoot, primary root   
 (C) secondary root, primary shoot  
 (D) bud, leaf.



4. An object is kept at the centre of curvature of a concave mirror. The position and nature of the image formed is 
- (A) between  $F$  and  $C$  and inverted
- (B) behind the mirror and erect 
- (C) between  $F$  and  $P$  and erect
- (D) at the centre of curvature and inverted. 
5. The power plant in which natural source of energy is directly used to rotate turbines is 
- (A) thermal power plant
- (B) hydro-electric power plant 
- (C) nuclear power plant
- (D) solar power plant. 
6. An example for saturated hydrocarbon is
- (A)  $C_2H_6$  
- (B)  $C_3H_4$
- (C)  $C_2H_2$
- (D)  $C_2H_4$ . 



7. The incorrect statement related to thyroxine hormone among the following

is



(A) it regulates fat metabolism

(B) its deficiency leads to goitre



(C) it is secreted by parathyroid gland

(D) iodine in the food is essential for its production.



8. The molecular formula of three carbon compounds which are in homologous series are  $C_2H_6$ ,  $C_3H_8$ ,  $C_4H_{10}$ . The suitable general

formula for these compounds is



(A)  $C_n H_{2n}$



(B)  $C_n H_{2n-1}$

(C)  $C_n H_{2n-2}$

(D)  $C_n H_{2n+2}$



II. Answer the following questions.



$8 \times 1 = 8$

9. An iron ring is to be coated with copper. How can we do this without using

electricity ?



10. What is the SI unit of potential difference ? Name the device used to

measure the potential difference.



11. "The rate of breathing in aquatic organisms is much faster than that seen in terrestrial organisms." Why ?



12. Sodium and potassium are placed in the same group of modern periodic table. If the molecular formula of sodium sulphate is  $\text{Na}_2\text{SO}_4$ , then decide the molecular formula of potassium sulphate. Give reason for your answer.

13. "Biogas plant is a boon to farmers." Why ?

14. The gene for brown coloured hair is recessive over gene for black coloured hair. What is the hair colour of a person who has inherited a gene for brown coloured hair from mother and black coloured hair from father ?

15.  $\text{CuO} + \text{H}_2 \rightarrow \text{Cu} + \text{H}_2\text{O}$

In this reaction name the reactant

i) that is oxidised

ii) that is reduced.

16. Observe the given figure.

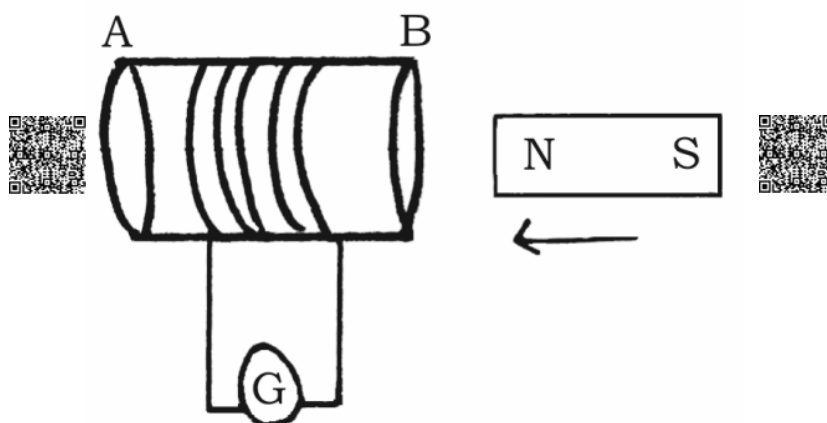

What type of current is induced in the coil by doing the experiment related to this figure ? Give reason for your answer.

III. Answer the following questions.

8 × 2 = 16

17. Agricultural scientists have suggested to add a certain amount of lime powder to an agricultural field. What may be the reasons for this ?

Explain.

18. "The body temperature of frogs and lizards depend on temperature in the environment." Justify.

19. Draw the diagram of the apparatus to show that acid solution in water conducts electricity. Label the following parts :

i) Dil. HCl solution

ii) Rubber cork.

OR

- Draw the diagram of arrangement of the apparatus to show the reaction of zinc granules with dilute sulphuric acid and testing hydrogen gas by burning. Label the following parts :

i) Test tube

ii) Soap solution.

20. The resistivity of manganese wire of length 1 m is  $1.84 \times 10^{-6} \Omega \text{ m}$  at  $20^\circ\text{C}$ . If the diameter of the wire is  $3 \times 10^{-4} \text{ m}$ , what will be the resistance of the wire at that temperature ?

OR



Observe the given circuit :

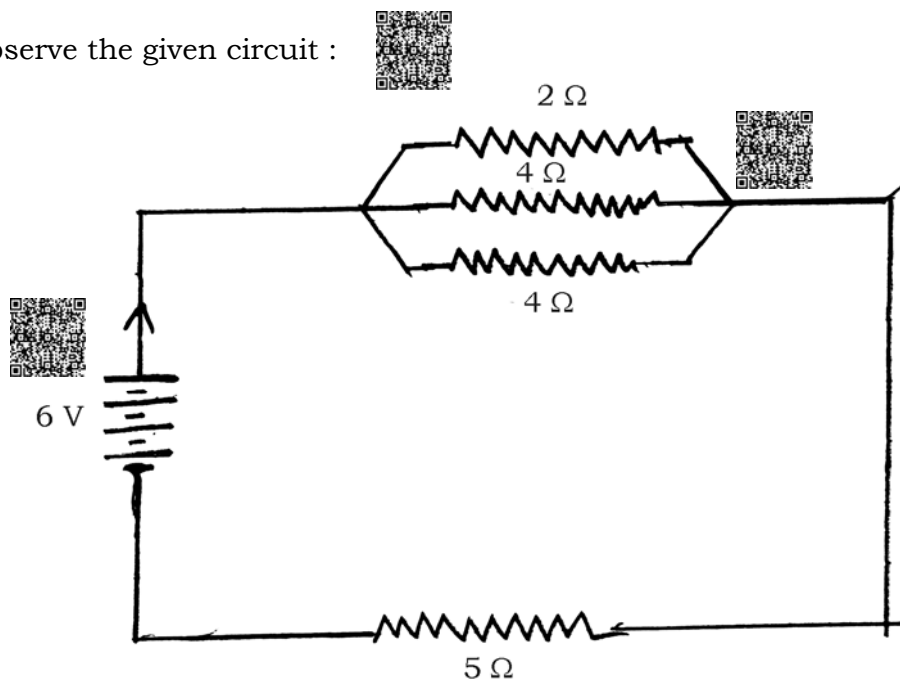

Calculate the total resistance in the circuit and the total current flowing in the circuit.

21. "As energy moves progressively through various trophic levels of food chain it is no longer available to the previous level." Give reasons.
22. Which physical properties of metals are used in the following situations ?
- Gold is used to make ornaments
  - Nickel is used in strings of guitar.
23. Draw the diagram showing the germination of pollen on stigma and label the pollen tube.
24. Draw the diagram of a simple electric generator. Label the following parts :
- Brushes
  - Rings.

IV. Answer the following questions.

9 × 3 = 27

25. State Joule's law of heating. Explain the working of electric filament bulb.

OR

State Ohm's law. How ammeter and voltmeter should be connected in electric circuit? What is the use of these instruments, in the circuit?

26. The reaction of Barium chloride with Aluminium sulphate solution is an example for which type of chemical reaction? Why? Write the balanced chemical equation for this reaction.

27. Explain the significant function of each structure in human male reproductive system.

OR

Explain the structure and important role of placenta during pregnancy period of woman.

28. Explain the addition and substitution reaction with the help of examples.  $C_2H_6$  undergoes substitution reaction but not addition reaction. Why?

OR

Explain how soap cleans clothes. More amount of soap is required to clean the clothes in hard water. Why?

29. "Building crescent shaped earthen embankment in level terrain is better than the construction of large dams across the river to store water." Analyse this statement with their effects.



30. An object is kept on the principal axis of a concave mirror of focal length 12 cm. If the object is at a distance of 18 cm from the mirror, calculate the image distance. Determine the nature of the image formed by calculating the magnification produced by the mirror.

OR

A doctor prescribes a corrective lens of power  $-0.5$  D to a person. Find the focal length of the lens. Is this lens diverging or converging? Give reason.

How does the property of this lens can be used to correct eye defects?

31. Draw the diagram showing the schematic sectional view of the human heart. Label the following parts :

- i) Aorta
- ii) Pulmonary veins.

32. Draw the ray diagram when the object is kept between  $F_1$  and  $2F_1$  of the convex lens. With the help of the diagram mention the position and nature of the image formed. [ $F_1$  : Principal focus of the lens]

33. The atomic numbers of two elements are 8 and 16 respectively. Write the electronic configuration of these two elements. Do you keep these two elements in the same group of the modern periodic table? Justify your answer. Find out which of these two elements is more electronegative. Give reason for your answer.

V. Answer the following questions.

4 × 4 = 16

34. Name the given structure. What is its general function ? Mention the function of the parts labelled as A and B. These structures in animals are said to be more efficient to give quick responses. Why ?

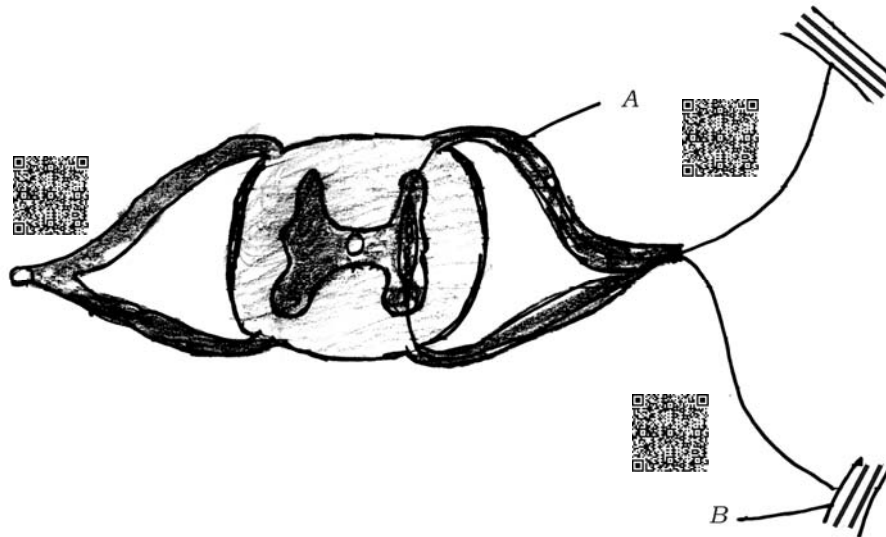

35. Mention the difference between calcination and roasting. How these processes are used in the extraction of zinc ? Explain with the help of chemical equations. After these processes, is reduction necessary to obtain zinc ? Why ?
36. How do you trace the magnetic field lines around a bar magnet using compass needle ? Explain. Write the properties of magnetic field lines.
37. The plants bearing round yellow coloured (  $RrYy$  ) seeds are self pollinated. Represent the result obtained in the  $F_2$  generation of dihybrid cross with the help of a checker board. Mention the varieties of plants obtained in  $F_2$  generation.

OR

What is evolution ? Explain the three evidences for evolution.

VI. Answer the following question.



1 × 5 = 5

38. Explain the experiment conducted by Newton to show that white light contains seven colours. Sun appears red in colour during sunrise but appears white at noon. Explain with the reasons.

